

VULCAN STOVE PARTS LIST (Pre 2021 model)

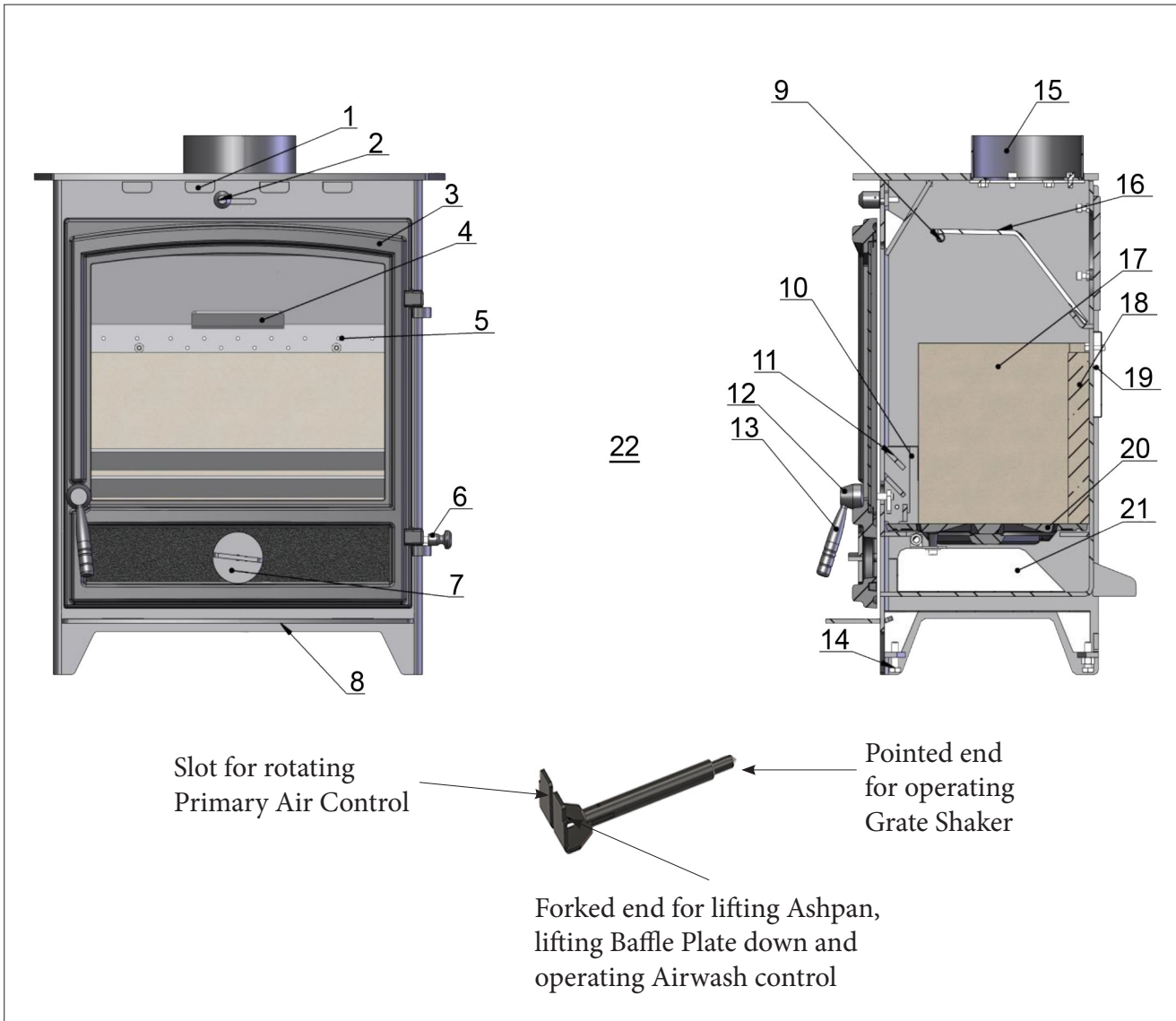

No	DESCRIPTION
01	Airwash Intakes
02	Airwash Control
03	Door
04	Rear Baffle Support
05	Tertiary Air Inlets
06	Grate Operating Knob
07	Primary Air Control
08	Ashlip
09	Baffle Support Pin
10	Firebox Side Liner Retainers
11	Fuel Retainer
12	Door Knob
13	Door Handle
14	Adjustable Feet
15	Fuel Spigot Collar
16	Baffle Plate
17	Side Firebox Liner
18	Rear Firebox Liner
19	Tertiary Airbox
20	Grate
21	Ashpan
22	Multi Tool