



Integra Balanced Flue Remote Control

Inset Live Fuel Effect Room Sealed Fire



Installation and Users Instructions

These instructions should be read by the installer before installation and then should be handed to the end user when the installation is complete.

This is an official requirement and is the responsibility of the fitter of this appliance.

Having installed the appliance, the installer should take the necessary steps to ensure that the user fully understands how to operate the appliance and is also made aware of the fire's basic cleaning and maintenance requirements.



SECTION	PAGE
Notes for the Installer and End User	3
Appliance Data	4
Appliance Dimensions	4
Recess Dimensions	5
Installation Requirements	5
Terminal location	6
Site requirements	8
Ventilation	8
Preparing the Outside Wall	8
Installation Procedure - Standard 22" x 16"	9
Installation Procedure For Decorative Cast Surround	11
Commissioning	11
Modular Coal Layout Instructions	12
Trouble Shooting (Gas Safe Engineer only)	12
User Instructions	16
Cleaning and Maintenance	21
Guarantee	21
Replacement Parts	22



Important notes before installation

This Balanced Flue product is a High Efficiency, Inset Live Fuel Effect appliance. This appliance will generate heat through both radiation and convection, using "room sealed" technology that requires no additional ventilation as it takes combustion air and deposits its Flue gases outside the house using its concentric flue system. The appliance has been designed to fit various installation situations, as detailed later in these instructions.

This appliance has been designed, tested and manufactured to BS EN 613: 2001 +A1: 2003 + C1: 2008 relating to Balanced Flue Appliances and must be installed by a qualified Gas Safe Registered Installer in accordance with the Gas Safety (installation and use) regulations 1994 and all other relevant standards.

This fire is a very effective heating appliance and must be fitted against a wall of non-combustible material as classified in BS 476-4:1970 (2007)

The installation must be undertaken by a competent person in accordance with Gas Safety (Installation and Use) Regulations 1998. The person should be on the Gas Safe Register which is the official list of gas engineers who are qualified to work safely and legally on gas appliances and are approved by the HSE under the above regulations. The installation must adhere to the requirements of the local and national Building regulations and national standards. These instructions are to be fully read before commencing the installation and the information must be followed. After installation they must be left with the user for reference and safekeeping. This appliance must be installed in accordance with the rules in force and only used in a sufficiency ventilated space. No additional ventilation is required, as the appliance does not use air from the room for combustion or operation of the Flue. However an adequate supply of fresh air to maintain temperatures within limits and a comfortable living environment is advised. This appliance is factory set for operation on the gas type and pressure as stated on the appliance data plate. No other gas or pressure should be used. Before installation, check that the local distribution conditions, nature of gas and pressure, and adjustment of the appliance are compatible. The appliance is intended for use on a gas installation with a governed meter. Ensure that the Flue Terminal is not in any way obstructed and is clear of vegetation, i.e. trees, shrubs etc. and that no objects are leant against the terminal or guard. Only flue components approved by Legend Fires for this appliance may be used.

WARNING: Do not operate this appliance if the glass panel is broken (or cracked), removed or is open. Always clean the window panel before the fire is ignited. Any finger prints must be removed, as these will be burnt into the glass and will be un-removable.

This appliance is designed as a heating appliance, and as such will get very hot in operation, all surfaces (except the controls and access door) are considered to be working surfaces and as such not be touched. The front window and surround are not considered to be fully secure guards against accidental contact. It is recommended that an approved fire screen be used if children, the elderly or persons with limited mobility are to be present in the same area. Do not place curtains, laundry, furniture etc. within a safe distance of 600mm of this appliance. Do not attempt to burn rubbish on this appliance.

If this appliance is extinguished, on purpose or other, no attempt to relight should be made within 3 minutes.

APPLIANCE DATA



Gas Type and Category	G20 Natural Gas Cat: I _{2H}	
Inlet Pressure	20 mbar	
Max. Energy Input	Gross 4.5 kW	Nett 4.1 kW
Max. Gas Rate	0.43 m ³ /hr	
Min. Energy Input	Gross 1.5 kW Nett 1.4 kW	
Min. Gas Rate	0.14 m ³ /hr	
Efficiency Class	1	
NOx Class	5	
Injector Marking	280 Stereomatic [elbow]	
Gas Inlet Connection	8mm	
Ignition	Piezo Spark	
Spark Gap	3mm (±1.0mm)	
Country of Destination (use)	AT, CH, CY, CZ, DK, EE, ES, FI, GB, GR, HR, IE, IT, LT, LV, NO, PT, RO, SE, SI, SK, TR	

APPLIANCE DIMENSIONS

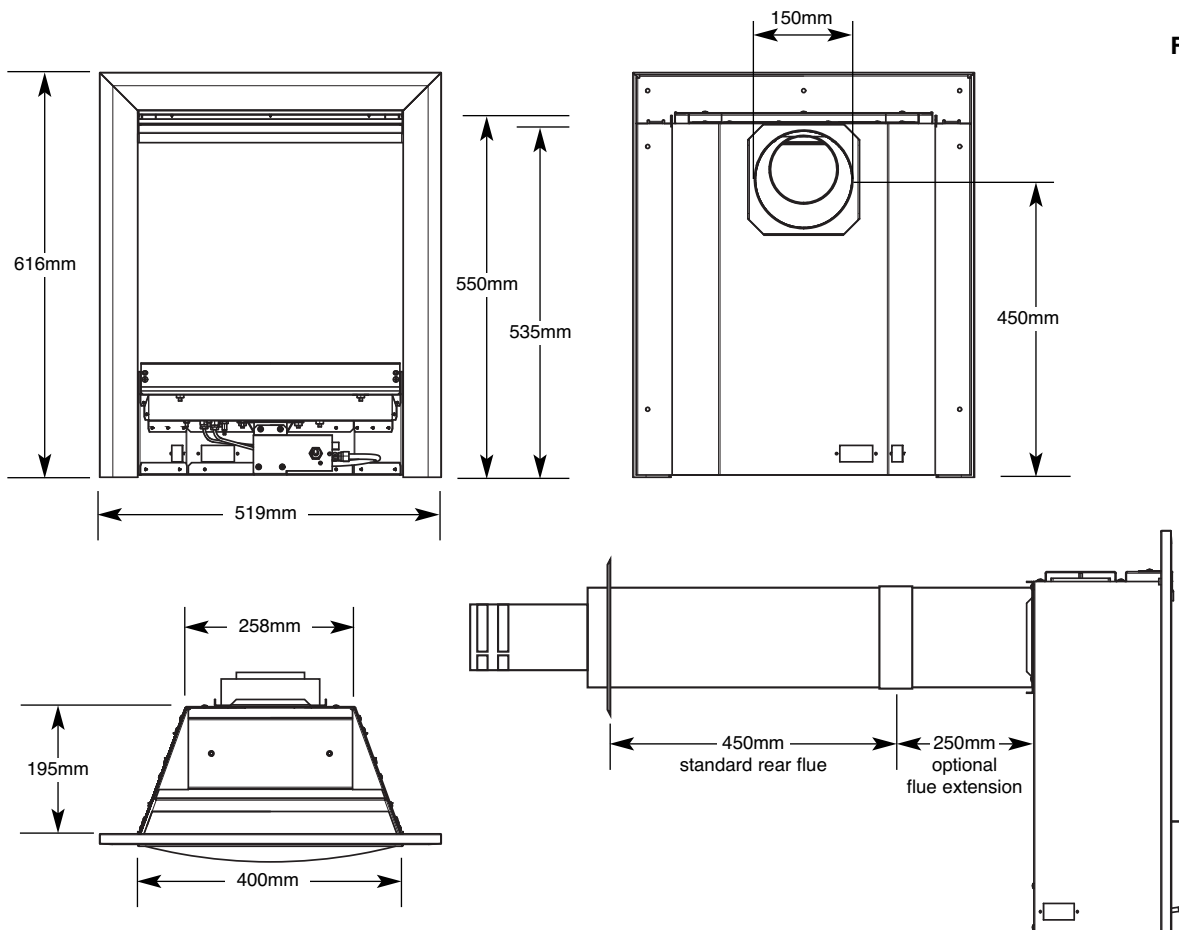

RECESS DIMENSIONS



A - Opening Width min. 410mm max. 450mm

B - Opening Height min. 560mm max. 583mm

C - Recess Depth min 200mm

INSTALLATION REQUIREMENTS

This appliance has been designed to fit into two main categories of installation. The first is to fit into an opening created in the inner leaf of an external wall or secondly into a false chimney breast or extended fire surround built to conceal the appliance. The appliance can also be fitted into an unserviceable or inoperative fireplace served by a disused natural draught flue, provided that the requirements for terminal location and flue length can still be successfully met. It is recommended that the old flue be sealed off. The Flue pipe must be able to pass right through the outside wall to duct fresh air in to the appliance and exhaust gasses out correctly. The Flue terminal must be screwed to the outside wall, with both of the pipes of the flue fitting onto the spigot on the fire.

The appliance is to be installed onto a suitable non-combustible surface at least 12mm thick, which must cover the entire base area of the box. The appliance must be installed with a fire surround and or back panel set capable of withstanding 180°C. Any combustible materials directly behind the fire frame (or back panel) and close to the appliance must be removed and replaced with noncombustible material such as cement, browning, "Superlux" board or equivalent materials.

The standard flue terminal length is 450mm, however this may be cut down using either tin snips or a grinder to a minimum length of 100mm.

The Flue terminal requires adequate clearance from other buildings, openings and obstructions to operate correctly and safely. Please refer to the Terminal Locations section. Terminals exhausting in passageways, over footpaths etc. may be subject to local bye-laws, and must not create a nuisance. If in doubt contact your local council for further advice. In some instances it may be necessary to fit a safety cage to ensure no problems arise. Avoid locating the terminal outlet close to combustible materials e.g. drain pipes, fences etc. if it is unavoidable, a metal deflector must be used if the object is significantly heated. Covered areas such as car ports or covered walkways should be avoided, but if necessary, the following guidance may be used; the covered area should have at least two open sides (i.e. it comprises roof and maximum one supporting wall). If more than one wall is filled, advice should be sought from Gas Safe on locations suitability. For minimum clearances see the terminal location section. Particular care should be taken with plastic roofs, if in any doubt the minimum distance stated should be to the lowest part of the roof.

As with any flue outlet, some discoloration of the wall around the terminal may occur with light coloured walls. Always avoid locating the terminal in conspicuous positions on light walls. Terminal location guidance is given in the next section but as a general rule avoid ledges, drain pipes, projections etc. The prevailing wind conditions combined with such objects can combine to produce unexpected conditions around the terminal.



Fig. 2

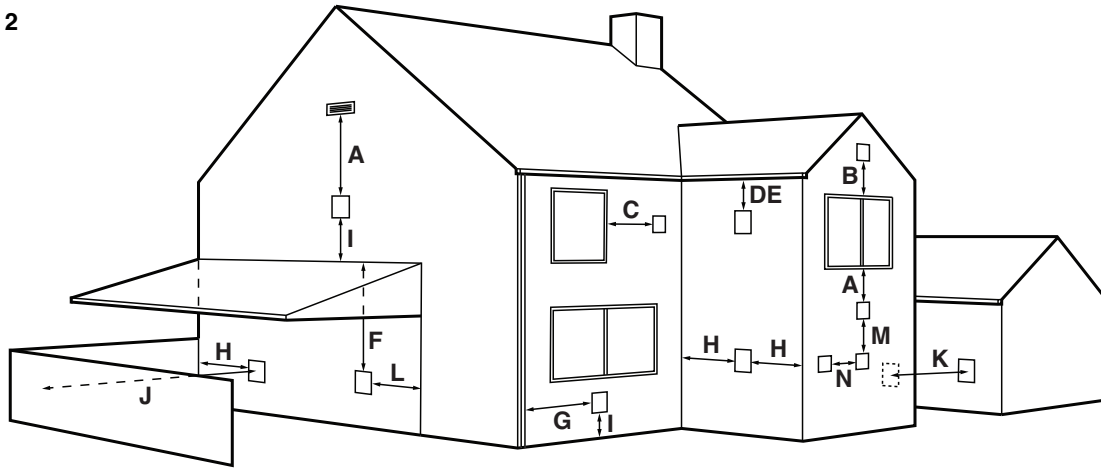

Dimension	Terminal Position	Minimum
A*	Directly below an opening, air brick, window etc.	600mm
B	Directly above an opening, air brick, window etc.	300mm
C	Horizontally to an opening, air brick, window etc.	400mm
D	Below gutters, soil pipes or drain pipes	300mm
E	Below eaves	300mm
F	Below balconies or car port roof	600mm
G	From a vertical drain or soil pipe	300mm
H	From an internal or external corner or to a boundary alongside the terminal	600mm
I	Above ground, roof or balcony level	300mm
J	From a surface or boundary facing the terminal	600mm
K	From another terminal facing the terminal	600mm
L	From an opening in a car port	1200mm
M	Vertically from another terminal on the same wall	1500mm
N	Horizontally from another terminal on the same wall	300mm

* In addition, the terminal should not be nearer than 300mm to an opening in the building fabric formed for the purpose of accommodating a built in element such as a window frame.

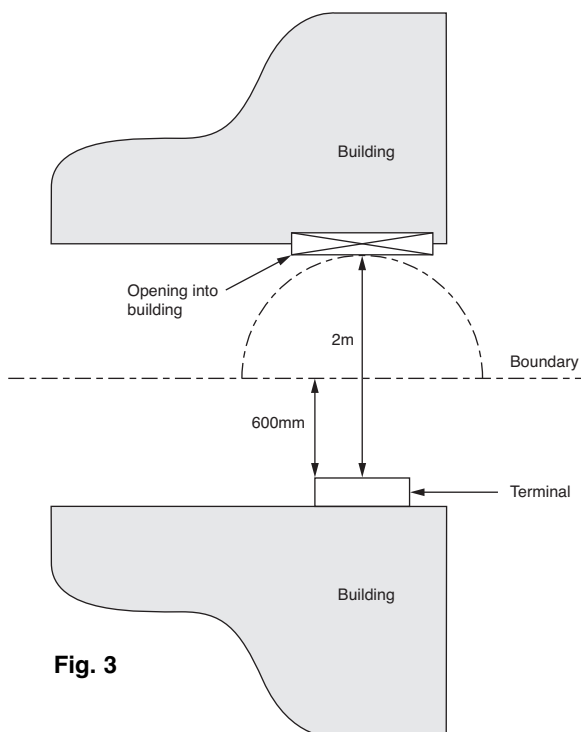

Fig. 3

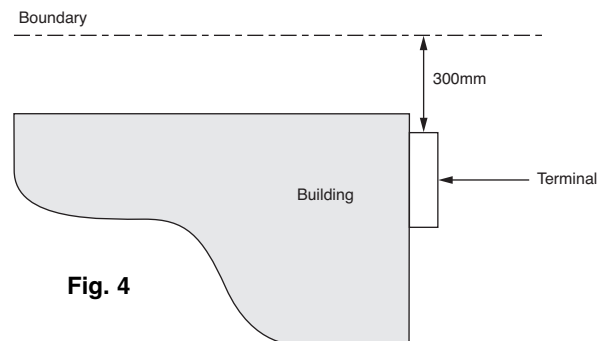

Fig. 4



Neighbourhood considerations

If a room-sealed gas appliance is fitted on that boundary wall, the flue terminal may extend into the neighbouring property. This may lead to a customer complaint, with allegations of trespassing and complaints of POC entering the adjacent premises.

The situation is compounded if the gas appliance is room-sealed and POC are blown onto neighbouring doors and windows. To add to the misery, in colder weather, the POC condense in the cold air to form a plume, which can be particularly irritating for the neighbour.

Be aware that installing an appliance in such a position may contravene the Gas Safety (Installation and Use) Regulations.

In addition, the neighbour may also have plans to develop or build an extension on their property, which may ultimately obstruct the flue outlet. When you are requested to install a gas appliance in these positions, advise the customer all the consequences. Such installations often offend neighbours who may contact local Planning or Environmental Health Officers who in turn may have powers under the Environmental Health Act 1990 to shut down an offending appliance. See also Exchanging Information with the gas user and planning - and Siting of flue terminals in relation to boundaries - care needed in this part.

Carport or building extension

Where you site a flue terminal within a carport or building extension, it should have at least two completely open and unobstructed sides. The distance between the lowest part of the roof and the top of the terminal should be at least 600mm for balanced flue appliances.

Note: Do not treat a covered passageway (e.g. between terraced houses) as a carport and do not install new appliances in this location.

Basements, light wells and retaining walls - points to note

Do not site flue terminals within the confines of a basement area, light well or external space formed by a retaining wall, unless you take steps to ensure that the POC can disperse safely at all times. It may be possible to locate room-sealed appliances in such a location provided that they are not sited lower than one metre from the top level of that area to allow POC to disperse safely.

Light well - an area that may inhibit dispersal of POC

A light well can be best described to cover areas where for example, there are walls opposite and/or around the wall on which a flue terminal is located, that may be inhibiting the free dispersal of POC. An illustration of this might be the common Victorian urban terrace property, where the front door opens onto the street footpath across a narrow well, which provides light and possibly access to a cellar. It may also be the small central area in a square building designed to give light to the rooms on the inside of the building.

Be aware of the dangers of locating flue terminals where the POC cannot freely disperse. This could be accentuated by the possible accumulation of POC caused by several flue terminals all discharging into a single confined space.

Terminal guards - when to use

Fit a flue terminal guard over a terminal:

- if anybody could come into contact with that terminal
- it could be subject to damage
- where the terminal is less than 2m from the finished floor level

The appliance manufacturer will specify a suitable terminal guard. No part of the guard should be less than 50mm from any part of the terminal when fitted in accordance with the manufacturer's instructions. The guard should not have any sharp edges, which could cause injury and any opening should be no larger than 16mm. Proprietary guards are generally available.

Timber frame construction - ensure no adverse effect on weather proofing

Whilst it is possible to install both open-flued and room-sealed appliances in timber frame properties, take great care to ensure that the chimney does not interfere with the weather proofing qualities of any outer wall it may penetrate.



This appliance may be installed by any of the following methods:

1. Fitting against the inside face of an external wall. A false chimney breast can then be suitably constructed or a rebated fire surround fitted to enclose the depth of the fire. If the false chimney is to be of a wooden construction, then clearances and insulation must be as for a timber constructed wall.
2. An opening in the inner leaf of a cavity wall may be constructed for insertion of the appliance. Bridging the cavity may cause unwanted moisture to track to the inside of the house from the cavity. Protection from moisture and falling debris above the cavity box should be provided. If in doubt, consult local building control officers. The appliance can also be fitted into an unserviceable or inoperative fireplace served by a disused natural draught flue, provided that the requirements for terminal location and flue length can still be successfully met. It is recommended that the old flue be sealed off.
3. Fitting into a timber framed house wall using clearances and insulation as described in the appropriate section. If in doubt, consult local building control officers.

The opening dimensions for inseting the appliance must be; WIDTH 410mm min. 450mm max, HEIGHT 570mm min 600mm max. The opening must be these sizes for the full depth of the cavity. Opening DEPTH must be 200mm minimum, this includes any plaster, cement or infill/back panels that form part on the installation. If a concealed gas connection is to be made, the supply pipe should always be sleeved through walls and floors using the shortest possible route. It is possible to install the gas supply from the side of the hearth and round into the cavity, but use only factory sleeved pipe. No more than 1.5m of Ø8mm pipe must be used to avoid unnecessary pressure drops.

The wall for the opening must be non-combustible or prepared as described in the relevant section. Bare plasterboard must be protected by non-combustible plaster or replaced with "Superlux" board, or other compatible material. Any gap between wall boards and the wall must be filled using glass fibre insulation, silicon mastic or similar method to prevent heat ingress. If the appliance is to be installed as a "hole in the wall" installation, it does not require any hearth as such, provided that the incandescent flame of the fire bed is at least 300mm above the floor level. If fitting the fire without a hearth, consideration should be given to the increased safety risk. The installer should inform the user of potential safety issues, including not placing combustible material directly in front of the appliance (floor covering such as carpet etc. is OK). The installer should use his judgement where necessary to advise against a hearthless installation. NOTE: it may be necessary to install a ledge for placement of the fire front, for this type of installation.

The appliance requires a hearth with non-combustible surface of at least 12mm thickness, projecting 100mm from the front of the appliance. The Top surface must be at least 50mm above the surrounding floor level, or be surrounded by a raised edge or fender 50mm high. Any type of fire surround used with this appliance must be adequately sealed to the wall and floor to prevent excess draughts from around the back of the appliance.

A combustible shelf may be fixed to the wall above the appliance, provided it has a maximum depth of 180mm and is 850mm from the hearth. The Shelf depth may be increased, however the shelf height must increased by 25mm for every 12.5mm of shelf depth (i.e. a ratio of 2:1). Combustible materials, such as wood, may be fitted to within 100mm of either side of the fire frame/trim, provided the forward projection does not exceed 100mm. Any combustible side walls must be at least 500mm to the side of the radiant heat source.

As with all heating appliances, any decorations, soft furnishings, and all coverings (i.e. wallpapers) positioned too close to the appliance may discolour or scorch.

VENTILATION

No additional ventilation is required, as the appliance does not use air from the room for combustion or operation of the Flue. However an adequate supply of fresh air to maintain temperatures within limits and a comfortable living environment can be beneficial.

For Republic of Ireland, see relevant rules in force.

PREPARING THE OUTSIDE WALL

From inside the house, firstly find the FINISHED HEARTH LEVEL, including any decorative hearth that will be in place when the fire is in position. This is the reference plane to which you should work. Mark the vertical centreline of the fireplace on the wall. Next, mark the centre of the flue pipe hole. This is 450 mm from the FINISHED HEARTH LEVEL. Pilot through the wall to ascertain the outside finished flue centre line. If necessary, check locations of wires and pipes in the wall first.

Check the outside flue terminal location using the pilot hole as a guide. Make any adjustments to the fire location or the surroundings as required to comply with terminal siting. Finally, core drill through the outside wall with a 155mm (6") core drill to provide the location for the outside part of the flue. If a core drill is not available, mark a 155mm diameter circle and stitch drill or chisel out the required area of brick. Clear rubble from the cavity and clear back any insulation material.

INSTALLATION PROCEDURE FOR STANDARD 22" X 16" OPENING



1. Carefully lift the appliance out of the packaging taking care not to damage the ceramic components in the separate carton.

2. Remove the magnetic trim and store to one side to prevent any damage.

3. Remove the louvered panel by lifting up and pulling forwards.

4. Slacken the five machine screws on the top retaining strip.

5. Unscrew the two securing screws from the lower infill panel and remove the panel. Tilt the glass forwards and slide out.

6. Cut the foam sealing strip (in plastic bag supplied) to length and stick a continuous strip down the two sides and across the top of the radiant box. When the box is placed against a flat surface the foam strip will form a seal around the boxes flange.

7. Carefully lift the appliance into position in the fireplace opening and check that the flange of the radiant box fits flush against the sealing face with no gaps present.

8. Measure from the inside wall surface to the outside wall face, this is Dimension X. Subtract **170mm** from Dimension X to calculate the length of the outer flue. Mark the finished flue length onto the outer tube, measuring from the terminal end.

9. Mark out four of the fixing holes. Remove the box and carefully drill and fit "Rawl" plugs or see alternative fixing page 10.

10. Split the flue tubes by removing the machine screw and using tin snips or a fine cutting disc, cut through the outer flue tube. Reassemble the flue tubes and measure 35mm from the cut end of the outer tube and mark the inner tube. Cut the inner tube and then secure the flue to the rear of the fire box using the clamp provided.

11. Decide which opening of the appliance the gas supply will be entering the radiant box and remove the relevant blanking plate. Feed the 8mm gas supply pipe through the opening from the rear of the fire and re-fit the blanking plate around the supply pipe.

12. Slide the fire and flue into the fireplace opening ensuring the flue locates into the hole in the brickwork. Ensure that the larger flue tube extends 25mm beyond the outer wall face when the fire is fully inserted into the opening and that the machine screw is located at the top of the larger flue.

13. Secure the box into place using four screws (straight shank screws are recommended for marble).

14. From outside, fit the cover plate over the large flue tube and secure with the two screws provided.

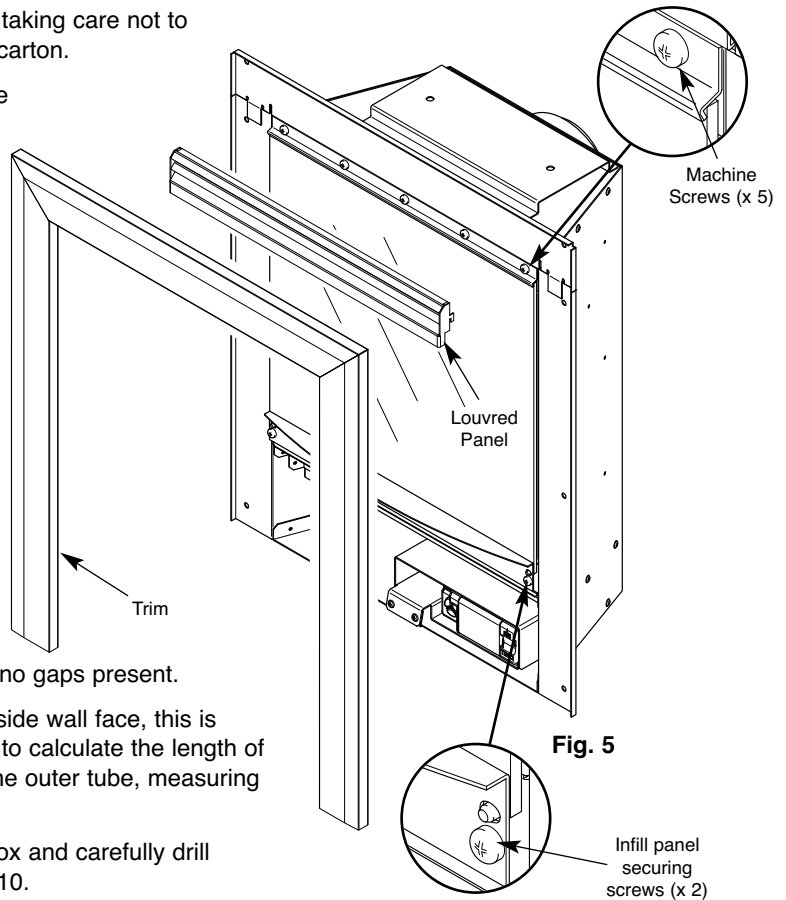

Fig. 5

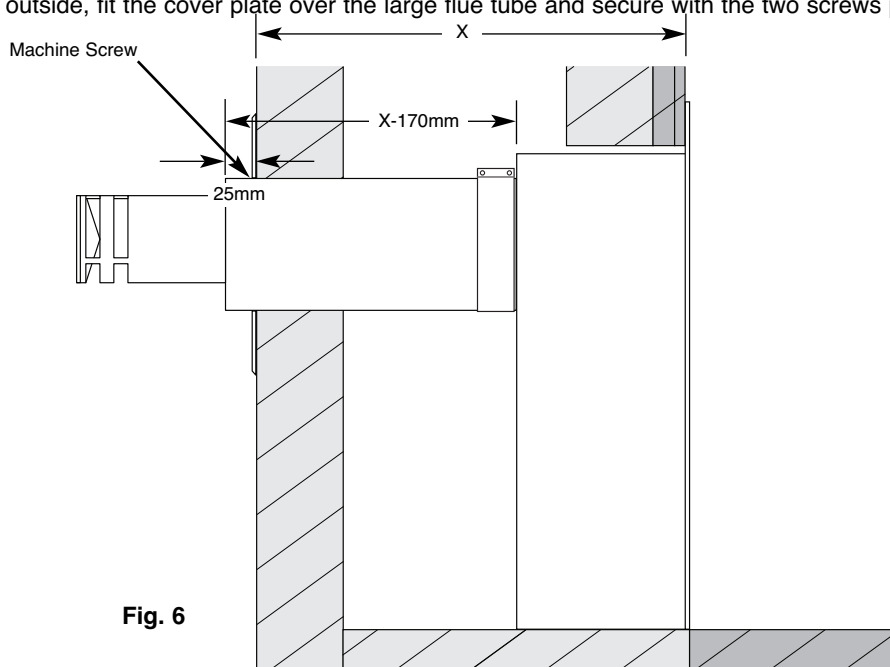
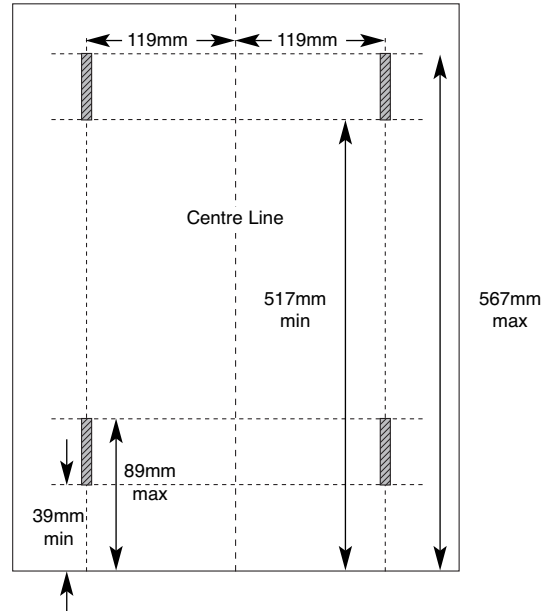

Fig. 6

INSTALLATION PROCEDURE FOR STANDARD 22" X 16" OPENING CONTINUED

Where the drilling of the back panel is not practical, an alternative fixing method may be employed using the optional cable fixing kit provided. Drill four holes in the rear of the fireplace opening. Securely fix the four eye bolts provided using suitable Rawl plugs. Feed one cable through each of the eyes in the rear of the fire box. Fix the box into the opening, securing into position using the cable fixing kit. Do not cut off the loose ends as the full length is required should the box need refitting at any time. Coil up and securely store underneath the burner tray.

Fig. 8



Drill holes for 4 eye bolts between max and min heights.

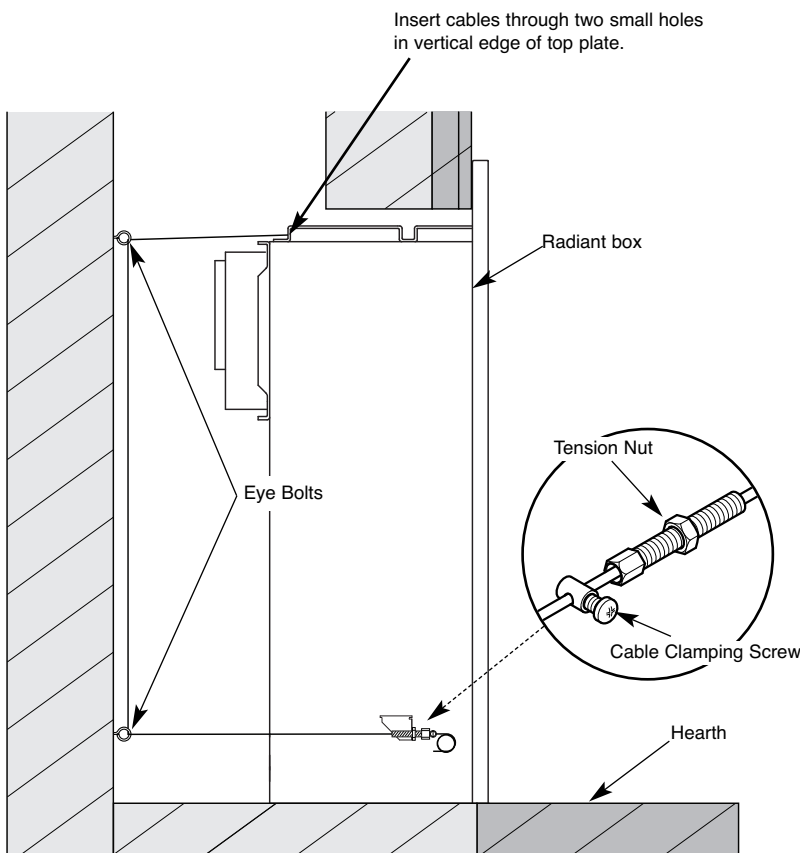

Fig. 7

INSTALLATION PROCEDURE FOR DECORATIVE CAST SURROUND



1. Install the decorative cast surround into the fireplace opening and ensure it is fully sealed including the open area above the fire (see Fig. 7).
2. Carefully lift the fire box out of the packaging taking care not to damage the ceramic components in the separate carton.
3. Cut the foam sealing strip (in plastic bag supplied) to length and stick a continuous strip up one side, across the top and down the other side of the rear of the radiant box. When the box is placed against the cast surround the foam strip will form a seal around the boxes flange.
4. Lift the fire box on to the two studs at the top of the surround and check that the flange of the radiant box fits flush against the sealing face with no gaps present.
5. Locate the decorative frame on to the studs and secure with the two nuts provided.
6. Insert the two screws into the lower holes in the decorative frame and carefully tighten ensuring the fire box is securely clamped between the frame and the surround.

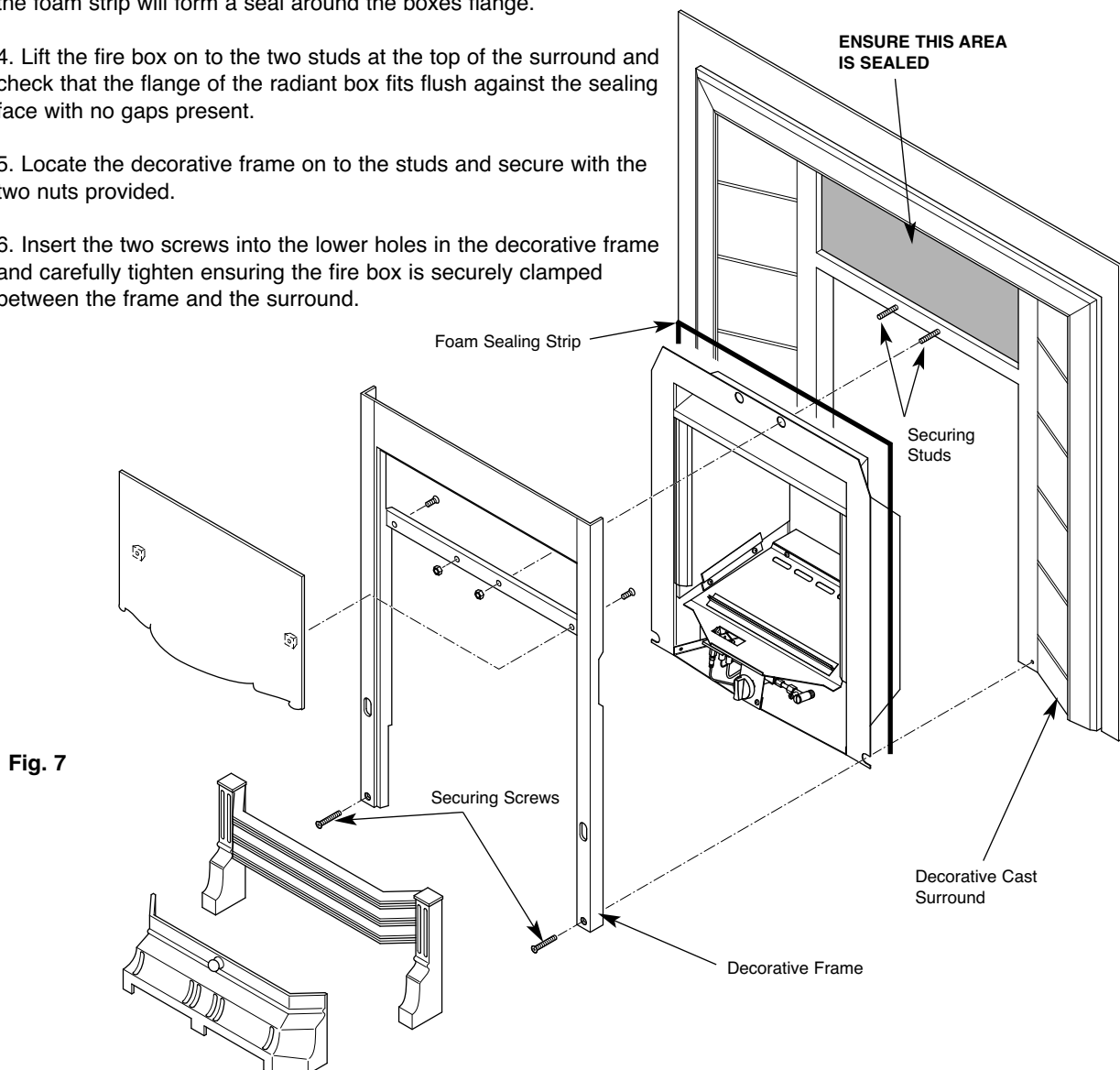

Fig. 7

COMMISSIONING

1. With the fire box installed in the opening, determine the length of 8mm gas supply needed and cut to length.
2. Before making the final connection, thoroughly purge the supply pipe to clear any foreign matter, i.e. masonry dust etc, as this could lead to blockages in the control valve and/or pilot assemblies.
3. Make the gas connection and carry out a gas soundness test.
4. Unscrew the inlet pressure test point sealing screw and fit a manometer. Ignite the appliance and turn to the high position.
5. Take a pressure reading and consult the technical data (page 4) to establish the correct working pressure.
6. Once the pressure has been checked and verified, turn off the appliance. Consult the ceramic component set up diagrams and fit the ceramics as per the instructions.
7. Re-install glass panel. The glass should be positioned centrally to ensure the decorative trim will fit over it.

MODULAR COAL LAYOUT INSTRUCTIONS



CAUTION: The coals are extremely fragile and must be handled accordingly. Gloves should be worn and any inhalation of dust should be avoided. The coals must be kept away from children at all times. Never put additional coals on the fire. Never use coals other than those originally supplied, or genuine Legend Spare Parts.

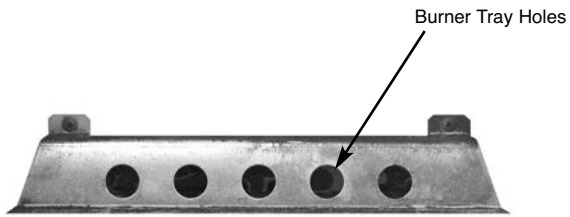

Fig. 9

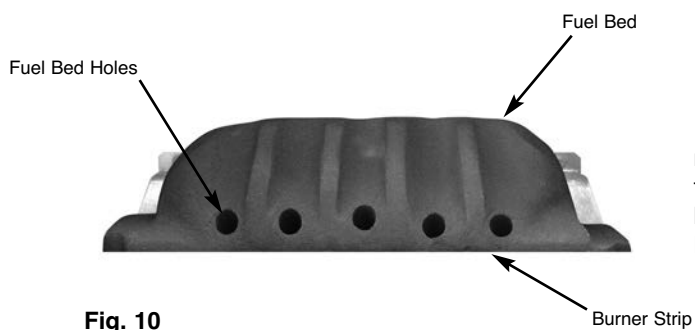

Fig. 10

1. Place the main fuel bed on to the back section of the metal burner tray. It is important that the front edge of the fuel bed is located behind the burner strip, and the holes in the fuel bed line up with the holes in the Burner tray (Fig. 10).



Fig. 11

3. Position the front coal piece on the front coal retainer, making sure that the back edge is pushed up against the front of the burner strip (Fig. 11).

4. Locate the remaining coal pieces in order as shown in Figs. 12 & 13.



Fig. 12



Fig. 13



5. Finally check that all the coal pieces are 'nested' together correctly (Fig. 14) and a close fit is achieved on the middle joint (this will stop gas surge through the gap).



Fig. 14

It is very important that all the coals are used and arranged as shown in order to achieve the desired flame picture.

It may be necessary to remove some or all of the coals to clean them at some time.
Cleaning must only be done using a soft brush.

TROUBLE SHOOTING (GAS SAFE ENGINEER ONLY)

NOTE: The purpose of the Error code is to give some information as to the potential reason for the fire not starting rather than just no flame. The appearance of an error code does not mean there is necessary a fault with the control or the appliance, it could be external factors outside the control that could cause error codes to appear from time to time and they could just be a one off event , so please check and work through the suggested service actions below before considering changing the control box. These codes are there to help with a more certain and efficient servicing of the appliance. Changing the box without working through the guide could lead to an unnecessary and expensive service and probably a repeat visit to fix the real fault.

SERVICING MUST ONLY BE CARRIED OUT BY COMPETENT PERSONAL WHO HAVE CURRENT QUALIFICATIONS AND ACCREDITATION (I.E. GAS SAFE)

NOTE: After correcting fault, perform a restart to reset error display to normal standby mode. Also depending upon the repair, air will need to be bled out of the system and it may take several start attempts to do so. E00 may appear and need to be reset a few times during the purging process, depending upon the length of supply pipe. Bleeding the supply pipe via the isolation valve pressure test point will help speed up this process.

NOTE: Before undertaking any actions on the servicing as detailed below , replace the batteries in the control and handset (if applicable) with new and know to be good batteries. Faulty batteries will cause error codes. There is a difference between old and faulty batteries and they may give false errors if the batteries are faulty.
ALWAYS CHANGE ALL THE BATTERIES TOGETHER AND NOT JUST ONE OR TWO AND ALWAYS OF THE SAME MAKE AND TYPE (I.E MANUFACTURER AND MODEL TYPE).

Generally : After replacing the batteries, to clear the error code perform a start cycle by pressing the start button as normal. Then press again in the same way to attempt a new start cycle. The error code must be cleared this way after every error code is displayed to start again.

TROUBLE SHOOTING (GAS SAFE ENGINEER ONLY)



Code	Comment	Appearance	Possible Cause	Action	
E00	TESC locked due to failed ignition	Red Led is permanently on TESC unit (and E00 on handset, if used)	Temporary air disturbance around pilot burner	Reset control by pressing start button for 1 second and releasing. Then press again the same way to attempt a normal start command. Repeat up to 10 times as necessary to see if this overcomes the issue as it may resolve itself eventually.	
			No gas on appliance inlet	Check to see if gas is present at gas appliance inlet. (Check gas supply is on, the gas line purged of air and the supply pipework is free of blockages or contamination)	Rectify and perform start cycle to clear the Error code. Try to light the fire as normal.
			Pilot contaminated with lint or other materials	Clean the pilot free of any dirt, dust carbon granules or lint, especially around the brass body of the bunsen burner and its gas and electrical connection and the area around the flame ports and the spark plug and electrode tip. Check the electrode gap is 3- 4 mm.	Rectify and perform start cycle to clear the Error code. Try to light the fire as normal. Replace pilot if necessary
			No Spark at Electrode (fire not igniting pilot burner)	Check ignition cable for damage and listen and watch for tracking out of spark to see if it is present but not making it to the electrode tip on the pilot burner.	If cable damaged, replace cable. Reset error by performing a normal start cycle and try to start again. Replace pilot if necessary.
			Pilot pipe or pilot injector could be blocked)	Clear pipe and consider changing pilot	
E01	Low current from thermocouple but flame; possibly CO alarm	Flashing Red LED on TESC Control	Pilot pipe blocked - no gas reaching pilot burner	Check pilot pipe, check flame appearance of pilot flames	
			Chimney blocked causing Co / Co2 to build up in the room build	Check flue	
			Pilot thermocouple defective / old	Change pilot or thermocouple	
			Possible temporary air disturbance on pilot flame	Clear error and restart to check ignition ok	
E02	Too high ambient temperature (>73 °C) around control		Negative flue pull or blocked flue or similar	Occurs if started ok then subsequently loss of thermocouple current. Check for flue problems. Fire cuts out to prevent over heating	Reset and try again
			Blocked flue	Check and clear	Reset and try again
			Poor position of Ceramic parts	Check manual for correct placement	Reset and try again
E03	No, defective, or bad connected thermocouple		Bad connection	Check if connected correctly and terminations are sound	Reset and try again
			Defective thermocouple	Replace Pilot	Reset and try again
E04	False flame signal		Occurs during stopping fire	Sensing flame on pilot when no flame should be there. Investigate.	Reset and try again
E05	False flame signal		Flame sensing on pilot before start of ignition sequence or after valve has shut off. Contamination of electrode to ground	Check and clean around the area of the pilot for lint and other contamination. Check where the thermocouple connects to the TESC control for the same contamination. Clean these areas.	Reset and try again
E06	Too low voltage on power supply to start the burner		Weak or old or defective batteries	Replace batteries	Reset and try again
E07	Power supply breakdown during peak current consumption		Check/change all the batteries or check power adaptor. : Note always change all batteries together never only 1 or 2	Replace batteries / power adaptor	Reset and try again
E08	Error caused by external pressure switch		Check the pressure switch	Replace if necessary	Reset and try again
	Jumpers on back of valve missing		Check to see if jumpers are in 10 way connector		Reset and try again
E09	Error caused by external pressure switch		Pressures switch action connection or jumpers missing or not connected properly	Check pressure switch connections, check to see if jumpers are in place on back of TESC.	Reset and try again
E10	Error caused by external pressure switch		Pressure switch action connection or jumpers missing or not connected properly	Check pressure switch connections, check to see if jumpers are in place on back of TESC.	Reset and try again
E11	Short circuit on wired thermostat (if used)		Check switch	Check switch for damage, contamination across terminals or damaged wiring. Disconnect wired thermostat if fitted and try a start, if it works replace thermostat	Reset and try again
E12	Open circuit on wired thermostat (if used)		Check wiring and thermostat	Check switch for damage, contamination across terminals or damaged wiring. Disconnect wired thermostat if fitted and try a start, if it works replace thermostat	Reset and try again
E13	Wired thermostat is out of tolerance		Check wiring and thermostat	Check switch for damage, contamination across terminals or damaged wiring. Disconnect wired thermostat if fitted and try a start, if it works replace thermostat	Reset and try again
E14	Button (-) sticks either on TESC or on wired control panel (if used)		Check for contamination around buttons	Clean as necessary. Replace switch panel as necessary if damaged or too contaminated. disconnect wired control panel and try again – if it works replace wired control panel	Reset and try again
E15	Button (+) is shorted to other buttons either on TESC or on wired control panel (if used)		Check for contamination/ damage	Clean as necessary. Replace switch panel as necessary if damaged or too contaminated. disconnect wired control panel and try again – if it works replace wired control panel	Reset and try again
E16	Button (ON/OFF) is shorted to other buttons either on TESC or on wired control panel (if used)		Check for contamination / damage and replace wired switch panel if necessary	Clean as necessary. Replace switch panel as necessary if damaged or too contaminated. disconnect wired control panel and try again – if it works replace wired control panel	Reset and try again

TROUBLE SHOOTING (GAS SAFE ENGINEER ONLY)



Code	Comment	Appearance	Possible Cause	Action	
E17	Button (-) is shorted to other buttons either on TESC or on wired control panel (if used)		Check for contamination / damage and replace wired switch panel if necessary	Clean as necessary. Replace switch panel as necessary if damaged or too contaminated. disconnect wired control panel and try again – if it works replace wired control panel	Reset and try again
E18	Button (AUX) is shorted to other buttons on switch panel		Check for contamination / damage and replace wired switch panel if necessary	Clean as necessary. Replace switch panel as necessary if damaged or too contaminated.	Reset and try again
E19	Infrared receiver defective (if used)		Check connection of IR or damage - replace if necessary IR eye	Check if wired correctly and replace IR eye if necessary	Reset and try again
E20	Illegal setup parameters		Check connection of IR or damage - replace if necessary IR eye	Check if wired correctly and replace IR eye if necessary	Reset and try again
E21	Tried to config a TESC as Clusterslave while a wired thermostat is connected		Factory assembly warning on setup configuration not a maintenance error	Usually only a factory assembly error. Could happen if done in error in servicing.	Reset and try again
E22	Tried to calibrate TESC with TESC easy test while a wired thermostat is connected		Not field error	Disconnect thermostat before attempting using Easy test unit.	Reset and try again
E23	Warning: end of life is near, should be replaced soon		Not field error	Indicated that control has performed a high number of operations and so fire should be serviced and control replacement should be considered as preventative maintenance. (should not really occur before 10 years from new).	Reset and try again
E24	Thermocouple doesn't reach final current - damaged or aged		Replace Pilot	Check and correct Thermocouple wiring. Replace thermocouple if necessary	Reset and try again
			Check pilot connections	Check and correct Thermocouple wiring. Replace thermocouple if necessary	Reset and try again
			Pilot pipe may be blocked completely	Clear pipe, replace pilot as necessary	Reset and try again
E25	Poor thermocouple signal		Tired or bad connection of thermocouple or bad or unstable flame on pilot or poor grounding return	Check pilot thermocouple connections and connections to TESC	Reset and try again
E26	Defective or wrong wired USB-power supply		Try again and if repeatedly fails replace	Replace with new USB power supply of the correct type.	Reset and try again
E48	Short circuit on thermocouple, or thermocouple reversed polarity		Wrongly wired	Check and correct Thermocouple wiring. Replace thermocouple if necessary	Reset and try again
E49	False flame signal		Flame detected during operation of fire when it should not be detected - contamination of electrode circuit to ground	Check if and clean around the area of the pilot for lint and other contamination and clean. Check where the thermocouple connect to the TSC control for the same contamination. Clean these areas.	Reset and try again
E50	Internal error		Flame detected during operation of fire when it should not be detected - contamination of electrode circuit to ground	Check if and clean around the area of the pilot for lint and other contamination and clean. Check where the thermocouple connect to the TSC control for the same contamination. Clean these areas.	Reset and try again
E51	Error caused by external pressure switch			Check pressure switch connections , check to see if jumpers are in place on back of TESC.	Reset and try again
E52	Error				Reset and try again
E27	Error				Reset and try again
E28	Error				Reset and try again
E29	Error				Reset and try again
E30	Error				Reset and try again
E31	Error				Reset and try again
E32	Error				Reset and try again
E33	Error				Reset and try again
E34	Error				Reset and try again
E35	Error				Reset and try again
E36	Error				Reset and try again
E37	Error				Reset and try again
E38	Error				Reset and try again
E39	Error				Reset and try again
E40	Error				Reset and try again
E41	Error				Reset and try again
E42	Error				Reset and try again
E43	Error				Reset and try again
E44	Error				Reset and try again
E45	Error				Reset and try again
E46	Error				Reset and try again
E47	Error				Reset and try again
E53	Error				Reset and try again
E54	Error				Reset and try again
E55	Error				Reset and try again
E56	Error				Reset and try again
E57	Error				Reset and try again
E58	Error				Reset and try again
E59	Error				Reset and try again
E60	Error				Reset and try again
E61	Error				Reset and try again
E62	Error				Reset and try again
E63	Error				Reset and try again



Warnings

All parts of the appliance become hot while running and should therefore be considered to be working surfaces.

A suitable guard may be required to take account of special hazards that exist in nurseries and other places where there are young children, aged or infirm persons.

Curtains are not to be placed directly above the appliance.

It is recommended that combustible materials are not placed directly above this appliance.

This appliance should not be used if the glass door has been removed, broken or is open.

Fire Control

This control is situated on your fire. The drawing shows the main features of the control.

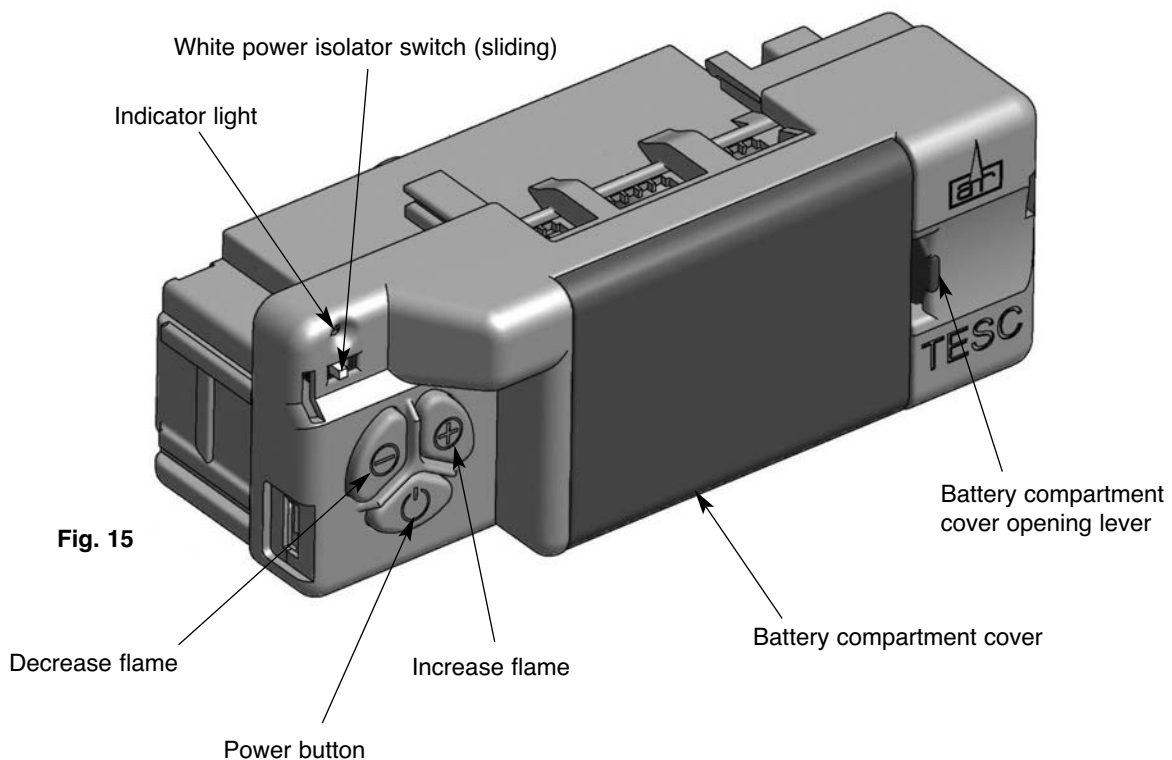

Fig. 15

Check the power isolator switch is in the On position (I).

To start the fire, press the power button and hold for 1 second then release. The burner will light within around 1 to 10 seconds, adjust to the maximum power setting.

The power of the burner can be adjusted up and down by pressing the – and + buttons.

To stop the fire, simply press the power button again and the burner will stop.

If for any reason the fire should be switched off, either intentionally or unintentionally, no attempt should be made to re-light the gas until at least 3 minutes have elapsed.

If you are not intending to use the fire for a long period (i.e. over summer time months), the battery life can be extended even more by sliding the white isolator switch to the left (away from the On position to (O)).



Handset

Ensure the Power Isolator Switch on the front corner of Fire Control is in the on position (I).

Note: For safety reasons a button must be pressed and released for the command to be recognised. Keeping hold of the button when pressing (unless otherwise instructed) will not be recognised as a command press.

Grasp around the handset to unlock its functions. The green unlock light will illuminate to show when the handset is unlocked and ready to accept commands. (N.B. Keep a grip of handset to keep it unlocked, to continue to operate the command buttons.)

Mode - MAN (Manual), Zzz (Snooze), thermostat or timed.

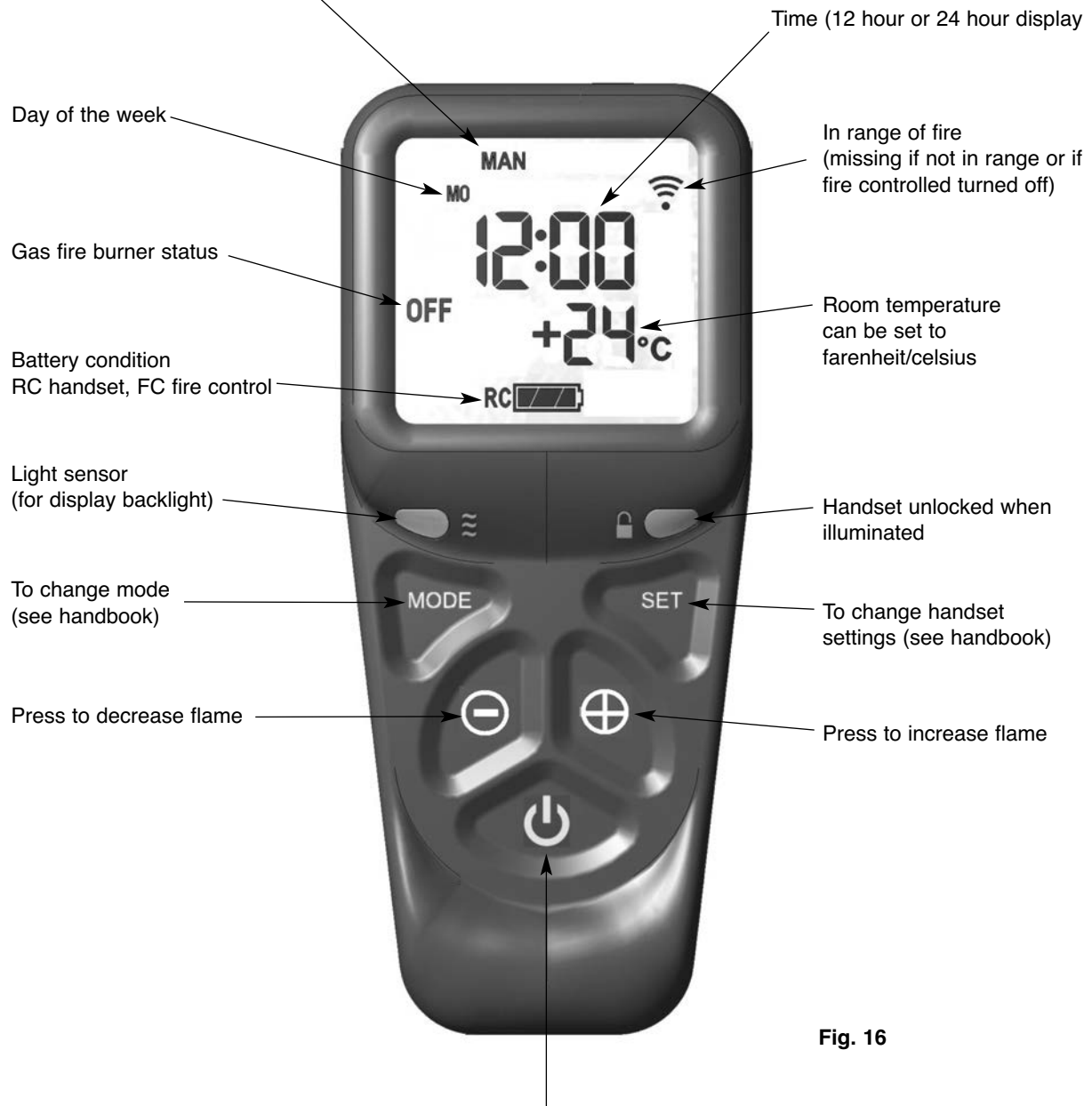

Fig. 16

Power button – To start the fire, (after ensuring the fire control is turned on as described above), with one hand grasp around the rear of both sides of the button area control. The green unlock light will illuminate. Keep the handset held to keep the control unlocked, to enable operation of the buttons. Then with the other hand touch and hold a finger on the power button for about 3 seconds. A short beep and a flash of the unlock light will happen upon touching. When the word “pilot” appears at the bottom left hand corner of the display, immediately release the power button. The Fire should be lit within a few seconds.

(N.B. If power button is held for more than a few seconds after second flash/beep/word pilot appears, the command is ignored for safety reasons. Similarly if it is released too soon before the word “pilot” appears, the command would also be ignored.



Operating instruction (Detailed)

THE HANDSET AND CONTROLS SHOULD ALREADY BE PAIRED AND THE DAY AND TIME SET CORRECTLY.

SHOULD ANY ADJUSTMENTS BE NECESSARY SEE INSTRUCTIONS BELOW:

Setting the time

Following pressing “SET” at pairing above, the display will be as shown, as the time is not set yet and will progress automatically to the next screen shown below.

Note: the legend at the bottom shows the battery condition of both the batteries in the hand set and in the fire control alternately. RC = Remote Control handset and FC = Fire control. The control is designed to get the most out of the batteries but when eventually the display shows they are spent (when the battery legend is a empty area, we recommend you change the batteries in the handset before they are flat, to avoid having to re-program the time of day in again.

N.B. Pairing is not lost, even if the batteries are removed or flat.



Fig. 17

Setting the display for 12 or 24 Hour display

As always when pressing the remote control buttons keep the control held to keep the green light on and therefore handset safety feature, unlocked. The H indicates that it is time to set the timer to either 24 hour display or 12 Hour (AM or PM) display. Press the + or – button on the handset to toggle between the two settings. When you are ready to confirm the setting you want press the “SET” button to progress to setting the day of the week.



Fig. 18

Setting the day of the week

Press and release the + and – buttons until the correct day of the week is shown on the display. (Mo = Monday, Tu= Tuesday, We=Wednesday, Th=Thursday, Fr=Friday, Sa= Saturday and Su=Sunday).

Press “SET” to accept the day of the week and to progress to setting the Hour of the day.

Note: Whilst doing this setup pressing “SET” advances to the next display and pressing “MODE” will return you to the previous display setting.



Fig. 19

Setting the Hour

Press and release the + or – button to change the hour to the correct hour and press set to store and to move to setting the minute. Repeat this for setting the minutes.



Fig. 20

Setting the temperature display to Celsius or Fahrenheit.

Press and release the + or - button to toggle between C and F. When the display shows the desired symbol, press and release the “SET” button to store.

As the important settings above have now been done. Press and hold (not releasing straight away) the “SET” button for a few seconds and this will exit the setup menu.

The control is now ready for use with the Fire Control.



Fig. 21



Paging the handset

If you have misplaced the handset you can page it by pressing the + button only on the fire control for around 5 seconds. The handset will flash and make a noise to help you to locate it. Once you pick up the TESC it knows you hold it and so the sound stops. The flashing and sound will last for 60 seconds each time the handset is paged as described. If not found in 60 seconds, page again and so on.

NOTE: Press “+” button ONLY, NOT “+” and “-” together. This will break the handset pairing and have to reset handset to factory state and pair again.

Advanced settings Menu

In the event that you may want to change the other preset settings of the control features. Do not do a long press and hold above but a normal short press and release will take you into the advanced settings area.

Advanced settings options are:-

- Back light –
 - A = Automatic (default setting). The back light comes on in the dark but not in the light.
 - 0 = Light never comes on.
 - 1 = Light comes on when ever handset is unlocked.
- Display contrast – 8 levels from 0 to 7 (default level 4) .
- P = pairing with other devices other than the fire control. The hand set can pair with other modules to:-
 - L= Operate an electric light – which is the dimmable in 9 steps
 - F= operate an electric fan –which can have 9 speed levels
 - A= operate an auxiliary contact to operate another device.

Other Modes than Manual Mode

Depending upon the model of Fire your handset maybe enabled to have some automatic features, namely, Thermostat mode, timed thermostat mode and snooze mode. Snooze mode can be selected to work with in conjunction with either manual or thermostatic modes. You can switch between modes at any time with the handset unlocked by pressing and releasing mode button to toggle between modes.

Note: If at any time the power button is pressed during operation, this will stop the fire and exit any automatic mode and return the handset to manual (MAN) operation mode.

Factory Reset of Display Handset (to enable handset to be paired again)

To reset a handset to factory conditions to enable it to be paired with a new control. Hold the handset to unlock. Press and hold set until handset beeps and release the set button. PROG will be at the top left corner. Press and release the mode button until the word SETUP is flashing in the top right corner.

Press and release SET to enter the SETUP menu.

Press and release the set button around 9 times until you see CA0 on the display.

Press then release the + (or – button) to change the display to CA1 and press and release the SET button again. The word TESC will appear in the window to show that this handset is now reset and ready to pair again.

Snooze mode in manual operation

Snooze mode is a time period you can set which will turn off the fire after a certain time period has elapsed.

The snooze time period can be set before or during manual operation of the fire. Hold the handset to unlock as described previously and press the mode button as many times as necessary until the word MAN and the Zzz symbols are flashing at the top of the display. Press and release the set button and this will put the control into Manual snooze mode.

The default time period for the snooze time period is 1:00 hour. Pressing the set button again will show you the snooze time period remaining. This can be adjusted by pressing the “+” or “-“ buttons. The timer period that can be set is from 1 minute to 4:00 hours.

After adjusting the time, press set again to enter the time setting required (or if left for a few seconds this time is now stored and used).

Once this countdown timer has reached zero the fire will turn off (as if you had pressed off manually, it does not recycle).



Snooze mode in Thermostatic mode

The same thing as above can be done before or during a thermostatic mode operation (see below).

Thermostatic mode only

The handset has within it a thermostat sensor and this can be set so the fire will heat the room to match the temperature set in the handset.

There are 3 temperature types that can be set:-

- Day mode temperature that has a sun symbol on the display – the default temperature is 24 °C
- Night temperature that has a half moon symbol on the display- the default temperature setting is 18 °C
- frost protection that has a snowflake symbol on the display – the default temperature setting is 5 °C

Hold handset and press and release the mode button several times as necessary until the display has a thermometer symbol flashing at the top of the display. Press the set button to enter this mode. Press the set button again to see the temperature setting that is set and the mode (the default is 24 C) and on the left of the display is a sun symbol showing it's the day temperature.

If a different set temperature is required, while the display is showing this set temperature , press the + and – buttons to alter the setting. When finished either press set or leave and after a few seconds the new setting will be accepted and the display will return to the time of day screen.

On the anniversary of the net minute of the clock, the set temperature will be compared to the actual temperature displayed on the handset(i.e. the room ambient temperature around the handset).

Note: If at any time the power button is operated during Thermostat mode, the control will cancel any thermostat operation and return the control to manual mode.

For ease of setting there are two other modes that can be selected as stated above. Night mode (moon symbol) and frost protection setting (a snow flake). These can be selected (and adjusted if necessary) by pressing set then mode while in thermostat mode. Pressing mode button toggles through from day to frost modes.

Note: As stated in an earlier section, snooze function can also be operated in conjunction with thermostat mode. The thermostat symbol and the Zzz symbol will be on together when in this mode.

Pairing the Handset to the Fire Control

Should the handset fail to operate the fire control, it may need to be re-paired with the system.

The handset must be within 1 metre (3 feet) of the fire when pairing.

After fitting the batteries as above (and with the power isolator slide switch on the TESC Fire control put in the on position), simultaneously press and hold the – and + buttons on the fire control (i.e. not the handset) until the handset makes a noise and the display shows the pattern as shown here.

Hold the handset in one hand so your fingers wrap around the back of the operating buttons area of the handset. A green unlock light will illuminate when the handset has detected your hand. The green light must be illuminated in this way for any of the command buttons to accept commands to operate the fire control.

While the display is as shown, and holding the handset as described, press the “SET” button with the other hand to finish off the pairing of the handset to the Fire Control and to enter the setup the time of day on the handset.

N.B. If the display returns to the one shown above with the word “TESC” shown, then too much time has passed before pressing “SET” and so the handset has not paired yet. Simply repeat pairing again.

N.B. Only ever press “+” and “-” buttons together when pairing handsets. If done afterwards this will break the pairing made and a factory reset of the handset will need to be performed, see Factory Reset of Display Handset later on in the instructions.



Fig. 22

CLEANING AND MAINTENANCE



It is recommended that this appliance is serviced at regular 12 monthly intervals. The flue should also be checked regularly to ensure that all products of combustion are entering the flue and there is no excessive build up of soot.

It is the user's responsibility to ensure that the appliance is kept in a clean serviceable condition.

To remove the glass

1. Remove the magnetic trim and store to one side to prevent any damage.
2. Remove the louvered panel by lifting up and pulling forwards.
3. Slacken the five machine screws on the top retaining strip.
4. Unscrew the two securing screws from the lower infill panel and remove the panel. Tilt the glass forwards and slide out.
5. Clean the glass with a damp cloth. For stubborn stains use a proprietary cream cleaner or ceramic hob cleaner.

Ceramic Components and Fuel Bed

Debris from any source should be removed with a soft brush.

Please ensure that any debris including soot deposits are removed from the appliance and not left on the fuel bed.

It is recommended that the user should, on a regular quarterly basis, carefully remove all ceramic components and thoroughly clean the stainless steel burner strip and the pilot assembly. Any build up of debris in this area could affect the operation of the appliance.

NOTE: It is common to find surface cracks in the ceramic components. This is due to the expansion and contraction of the ceramic fibres caused by the intense heat that the burner generates. The cracks will not affect the safe operation of this appliance. However, great care must be taken when handling the ceramic components as they will break if handled incorrectly. Do not use a vacuum cleaner to clean the ceramics.

Ceramic Liners - Use only a soft brush to remove any soot deposits from the ceramic liners during cleaning as this is the only method that can be used to remove deposits. The ceramic liners are very delicate and should be treated accordingly.

6. Reassemble in reverse order. The screws should be tightened enough to ensure the glass is sealed. The glass should be positioned centrally to ensure the decorative trim will fit over it.

Trims and Frets - The trim and fret should be removed from the appliance for cleaning, please ensure that the appliance has cooled thoroughly. Metal trims and frets maybe lacquer coated and therefore do not require polishing.

GUARANTEE

Your appliance is guaranteed for one year from proof of purchase. Should the appliance prove defective within that period we agree to repair or replace (at our discretion) the component or appliance provided that:

1. The user can produce a receipt for proof of purchase/installation.
2. The appliance has been supplied by an authorised stockist and has been installed by a qualified installer, all installation and operating instructions have been strictly adhered to.
3. No alterations have been carried out on the appliance or component parts without our written consent.
4. The appliance has not been used for any purpose other than those intended.
5. The appliance has not been damaged accidentally or due to fair wear and tear.

Guarantee claims should be made through your appliance supplier. The Guarantee is restricted to UK Mainland and is additional to your statutory rights.



1. Front Coal, Fuel Bed and Top Sections - All these ceramic components can be replaced at service intervals depending on their condition. If the coals do require replacement, the consumer can do so provided that the Ceramic Component Layout Instructions are adhered to. Only genuine Legend replacement parts should be used. (Order Ref: **Front Coal: EBFFC02 Fuel Bed: EBFM03 Top Sections: EBFTS04**)

2. Pilot Assembly - In the unlikely event of a pilot failure, the pilot assembly should only be replaced by a **Gas Safe Registered Engineer**. The user must not carry out this work. (Order Ref: **LEG226**)

3. Control Tap - In the unlikely event of control tap failure, the assembly should only be replaced by a **Gas Safe Registered Engineer**. The user must not carry out this work. (Order Ref: **LEG60**)

4. Main Injector - In the unlikely event of main injector failure, the fitting should only be replaced by a **Gas Safe Registered Engineer**. The user must not carry out this work. (Order Ref: **LEG280**)

5. Glass Panel - Should the glass become cracked or broken, the fire should not be used under any circumstance. (Order Ref: **LEG281**)

6. Glass Rope Seal - The integrity of the glass rope seal should be checked on service and replaced if necessary by a **Gas Safe Registered Engineer** (Order Ref: **LEG224**)

7. Plastic Coated Mild Steel Terminal Guard (Order Ref: **LEG286**)

8. Stainless Steel Terminal Guard (Order Ref: **LEG287**)



Unit 404 Glenfield Park Business Centre Blakewater Road Blackburn Lancashire BB1 5QH
Tel: 01254 695244 Fax: 01254 695255 Web: www.legend-fires.com Email: info@legend-fires.com